

## TANK QUESTIONNAIRE FOR DIPRODS

**PLEASE REMEMBER, THE GAUGE CAN ONLY BE AS ACCURATE AS THE INFORMATION YOU PROVIDE**

| GRP Diprod                                  |  |
|---|--|
| <b>*Full Tank Capacity</b>                  |  |
| Tank Number (if required)                   |  |
| Type of Liquid (if required)                |  |
| Safe Working Capacity (if known)            |  |
| Calibration Units<br>(e.g. Gallons, Litres) |  |
| <b>**Diprod Length</b>                      |  |
| <b>*Tank Shape</b>                          |  |

\* All fields in **Bold** are mandatory.

\*\*Recommended GRP diprod length – tank height plus approximately 1m unless specified

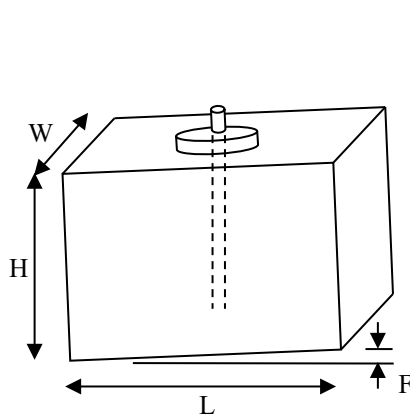

Rectangular  
(R)

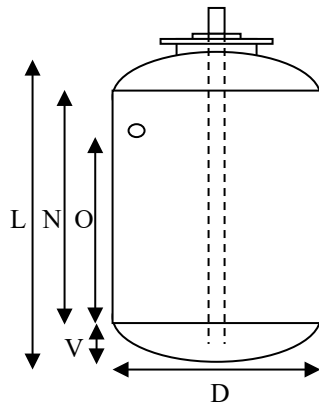

Cylindrical Vertical Flat/Dished  
(CVF or CVD)

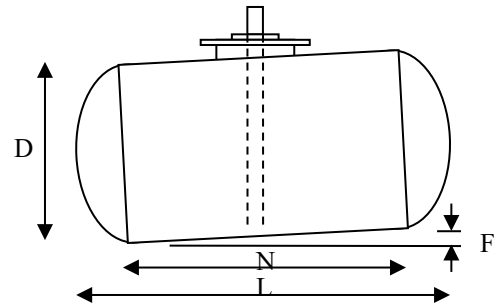

Cylindrical Horizontal Flat/Dished  
(CHF or CHD)

|                    |  |
|--------------------|--|
| <b>*Height (H)</b> |  |
| Width (W)          |  |
| Length (L)         |  |
| Fall (F)           |  |

|                    |  |
|--------------------|--|
| <b>*Length (L)</b> |  |
| Shell Length (N)   |  |
| Diameter (D)       |  |
| Overfill Point (O) |  |

|                      |  |
|----------------------|--|
| <b>*Diameter (D)</b> |  |
| Length (L)           |  |
| Shell Length (N)     |  |
| Fall (F)             |  |

|                              |       |                |
|------------------------------|-------|----------------|
| Customer's Name and Address: |       |                |
| Despatch Address:            |       |                |
| Customer's Order Number:     | Date: | Authorised By: |